

CA4-type (04) Receptacle for up to 100 kVDC

4-pin Federal Standard receptacle socket that complies to the NEMA XR-7 and IEC 60526 standards for X-ray cable plugs and receptacles.

Features

- Nickel-plated brass contacts pins directly moulded into receptacle with O-rings for excellent oil-seal.
- Thermoplastic material with high flame-retardant rating (UL 94-5VA), high insulation resistivity ($\geq 10^{15} \Omega \cdot m$) and high temperature resistance (130°C).
- Corona-free aluminium anode plate.
- Brass thrust ring with spanner wrench holes.
- Flat rubber gasket for oil-seal.
- Chromium-plated brass mounting flange for mounting on generator.

- Lead wires, potted end or custom machining available upon request.

Description

The receptacle is made from a UL 94-V0 and UL 94-5VA rated high insulating thermoplastic material with excellent chemical resistance to transformer oils and chemicals. The directly moulded nickel-plated brass contact pins are sealed with O-rings for an excellent vacuum-sealing. Standard packaging is one receptacle with brass nuts and a protection cap. The anode version also includes the anode plate. This receptacle is subjected to the Underwriters Laboratories "Recognized Component Service".

Optional mounting hardware

- Mounting flange with four holes
- Flat rubber gasket
- Thrust ring

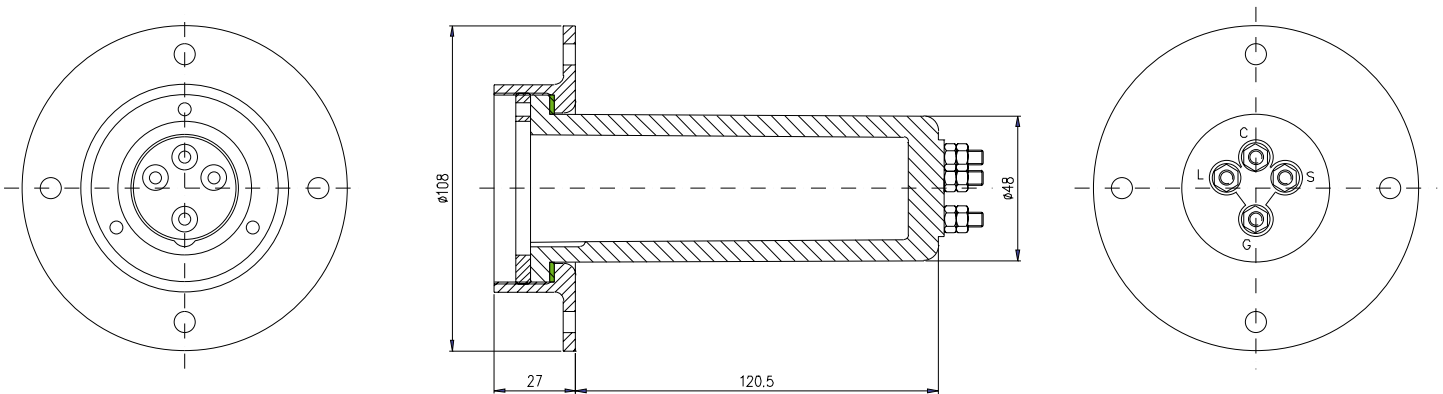

Technical data

Rated voltage between pins and flange	75kVDC
Type test voltage between pins and flange	150kVDC / 15min
Rated voltage between pins	4.3kVACrms
Type test voltage between pins	6kVACrms / 15min
Insulation resistance between pins	$>10^{15} \Omega$
Insulation resistance between pins and flange	$>10^{15} \Omega$
Maximum conductor current	25A
Material flame class rating UL 94 5VA	2.25 mm / 0.089 in
Maximum continuous operating temperature	130°C / 266°F